

Waters UPC <sup>2</sup> System with PDA detection and Empower 3	
REVISION NUMBER	1.4
DATE	October 11, 2018



**ACQUITY UltraPerformance  
Convergence Technology  
UPC<sup>2</sup>™ Operation with Empower 3**



## Table of Contents

Page #	Chapter #	Description
3	A	Objective
3	B	Supplies and Sample Setup
4	C	Empower 3 Login and Configuration Manager
9	D	Run Samples with UPC <sup>2</sup> Basic Navigation
11	E	Basic UPC <sup>2</sup> Daily System Startup
14	F	UPC <sup>2</sup> Instrument Methods and Method Sets
25	G	Making a Sample Set and Acquiring Data
28	H	UPC <sup>2</sup> Console and Diagnostic Checks

## A: Objective

Objective: This is a basic introduction to daily startup, acquisition and system diagnostics for the ACQUITY UPC<sup>2</sup> PDA system using Empower Software. This document covers basic overview and training for methods development of a UPC<sup>2</sup> system.

## B. Supplies and Sample Setup

1. UPC<sup>2</sup> aChiral columns:
  - Torus 2-PIC 1.7um 3.0x100 mm p/n 186007602
  - Torus Method Development Kit 3.0x 100 mm (2-PIC,DEA,Diol,1-AA) 4 pack p/n 176003580
  - Torus Method Screening Kit 2.1x 50 mm (2-PIC,DEA,Diol,1-AA) 4 pack p/n 176003579
2. UPC<sup>2</sup> Chiral columns
  - Trefoil Chiral Method Development Kit 3.0x150mm 3 Pack (AMY1, CEL1,CEL2) p/n 176003578
  - Trefoil Chiral Screening Kit 2.1x50mm 3 Pack (AMY1, CEL1,CEL2) p/n 176003577
3. Samples: Quantity 3 for all 3 sample experiments

186007950	UPC2 QC Reference Material  Test sample for both chiral and achiral modes. Designed for Trefoil, Torus, and Viridis Columns. Four compound mixture in 1 mL diluent of 75:25 Acetonitrile - Methanol. 0.50 mg/mL (+/-) trans-Stilbene oxide (chiral separation) test 0.50 mg/mL Thymine 0.50 mg/mL Sulfamethoxazole ( 254 m/z ms performance) 0.50 mg/mL Sulfamethizole
-----------	--

4. Empower 3 UPC<sup>2</sup> Startup project (included):
5. Detection: PDA
6. Co-Solvents:
  - B1: Methanol
  - B2: Acetonitrile
  - B3: Ethanol or Isopropanol
  - B4: Methanol/Acetonitrile Mix 50:50
7. Wash Solvents:
  - Seal Wash: Isopropanol
  - Weak Needle Wash: Methanol
  - Strong Needle Wash: Methanol: Isopropanol 50:50
8. Sample Diluents:
  - 80:20 Heptane/2-Propanol
  - 100% Methanol
  - 75:25 Acetonitrile - Methanol
  - Pipette 1mL of sample into a 5 mL volumetric flask, dilute to volume with above diluents.
9. Injection Volume:
  - 2ul to 8ul (Standard 10ul Sample Loop)
10. Instrument method:
  - Method and Sample Set conditions included in this guide
  - Use the included UPC<sup>2</sup> Empower project for start conditions.

### C: General aChiral System Strategy

1 <sup>st</sup> Pass UPC2 Screening Conditions		
<ul style="list-style-type: none"> <li>■ Bases                             <ul style="list-style-type: none"> <li>- Ammonium Hydroxide</li> <li>- Ammonium Acetate</li> <li>- <b>Ammonium Formate</b></li> <li>- Triethyl amine, diethyl amine, etc</li> </ul> </li> </ul>	Starting Conditions	UPC <sup>2</sup> Screening Columns: UPC2 Torus 2-PIC 2 <sup>nd</sup> Option: UPC2 Torus DEA Column
		Gradient: 2 to 50% Methanol in 5.0 min
<ul style="list-style-type: none"> <li>■ Acids                             <ul style="list-style-type: none"> <li>- <b>Formic acid</b></li> <li>- TFA</li> <li>- <b>Citric acid</b></li> <li>- Organic acids</li> </ul> </li> </ul>		Column(s): 3.0 x 100 mm, 1.7 µm
		Flow rate: 1.2 mL/min
		Injection volume: 1 µL
		Temperature: 30 -50 C
		ABPR: 2000 psi (140 bar)
	<ul style="list-style-type: none"> <li>■ Modifiers                             <ul style="list-style-type: none"> <li>- <b>Methanol</b></li> <li>- 2-propanol</li> <li>- Acetonitrile</li> <li>- Hexane</li> </ul> </li> <li>■ <b>Temperature</b> <ul style="list-style-type: none"> <li>- Selectivity effects</li> </ul> </li> <li>■ <b>Pressure</b> <ul style="list-style-type: none"> <li>- Elution effects</li> </ul> </li> <li>■ Solvent Blends</li> <li>■ <b>Gradient or Isocratic</b></li> </ul>	

### C: Empower 3 Login



1. Double click on the Empower icon. The default user name is **System**, and default password is **Manager** (the user name and password may be different if setup by your Empower System Administrator). Click on Run Samples



2. From Run Samples menu select the “UPC<sup>2</sup> Basic Training” Project or other UPC<sup>2</sup> defined project. Also select the Chromatographic System that was just created, “ACQUITY UPC<sup>2</sup>” System.

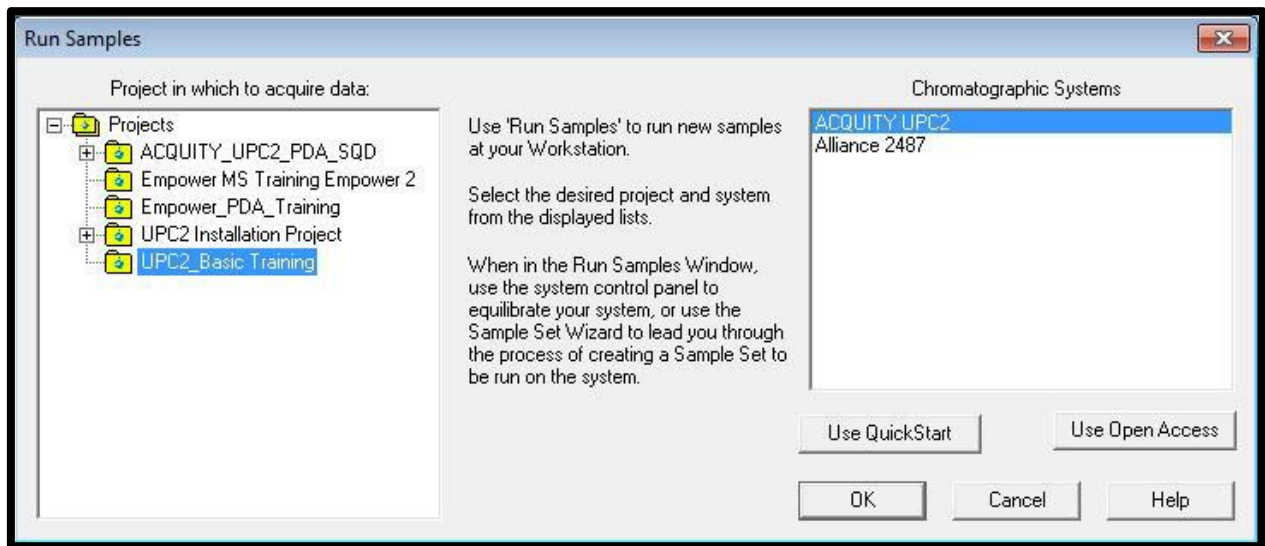

3. The Run Samples window has 5 general sections:

- A. Menu bar, Run Type and Table Preferences
- B. Sample Set table display
- C. Sample table selection tab (Single, Samples, Sample Sets, Running).
- D. UPC<sup>2</sup> console and direct control functions (details on the next page).
- E. Real time plot chromatogram and channel display of acquisition.

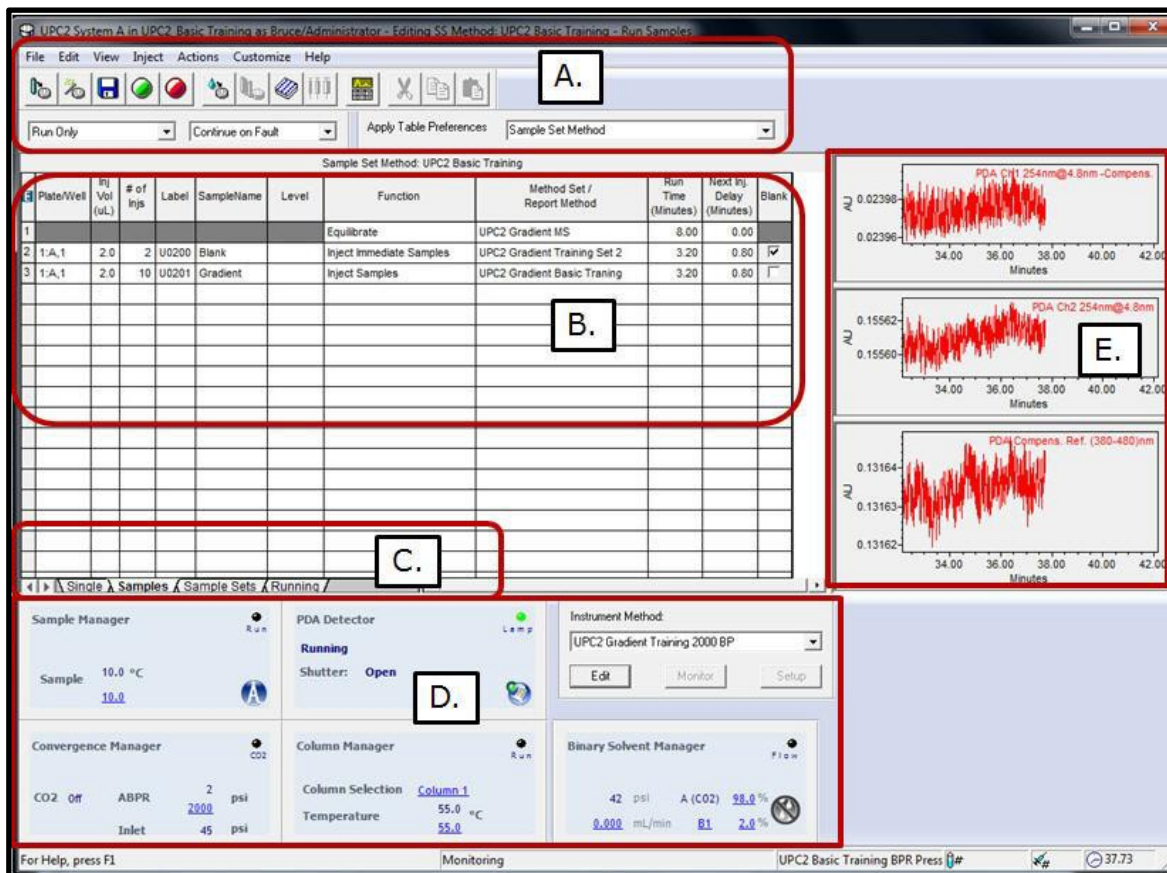

## E: Basic UPC<sup>2</sup> Daily System Startup

1. Before starting the UPC<sup>2</sup> system, make sure the desired sample loop, CO<sub>2</sub>, co-solvent, and samples are ready and placed on the system. Ensure the CO<sub>2</sub> tank is connected and the valve is in the open position.
2. Each UPC<sub>2</sub> module has individual controls that can be accessed with right mouse clicks. These include resetting a module in case of a failure, start and stop pump flow, and access of the full ACQUITY console for configuration and diagnostics. Each of the console controls are listed below.

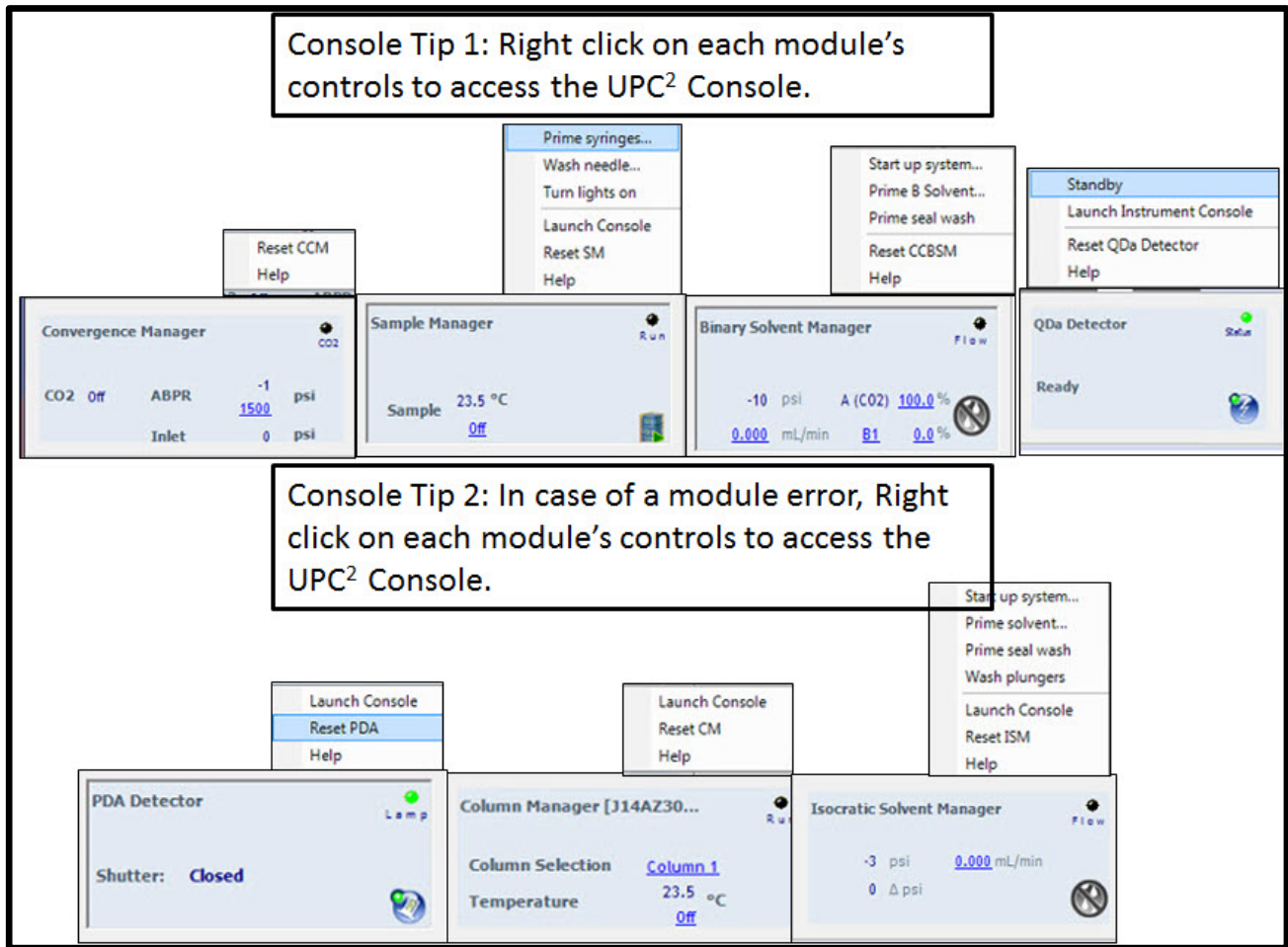

3. For startup, click on the Convergence Manager console's ABPR "Pressure Setting". Enter a pressure of 2000, and then click the check box. The ABPR starts pressurizing once the BSM starts pumping CO<sub>2</sub>.

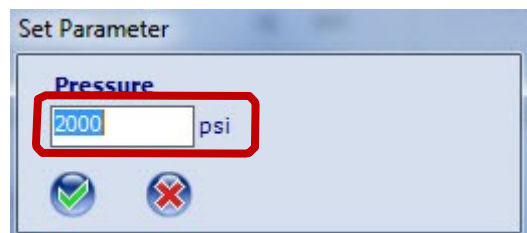



- Right mouse click on the Binary Solvent Manager and select "Start up system...".

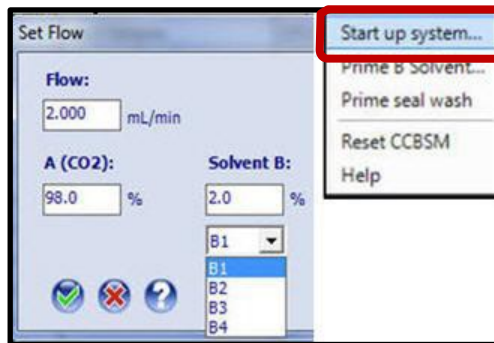

- For standard UPC<sup>2</sup> System Startup, use "Prime Solvents" tab and "Equilibrate to Method" tab (the "Optional: Characterize" tab is used when changing sample loops"). For the "Prime Solvent" tab use the following general recommendations.

	SM - Sample Manager - Cycles	CCBSM – Binary Solvent Manager Time
Overnight	2 Cycles	1-2 Minutes
Startup	6 Cycles	4 Minutes

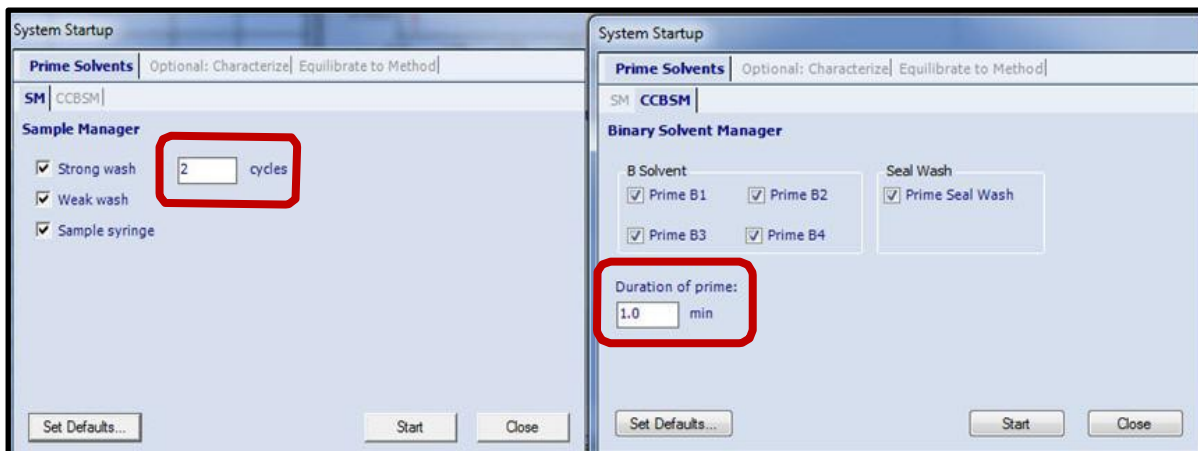

- For the Equilibrate to Method tab, select as per the developed method and click "Start" (below are some general startup conditions for a 3.0mm IDx100mm UPC<sup>2</sup> column).

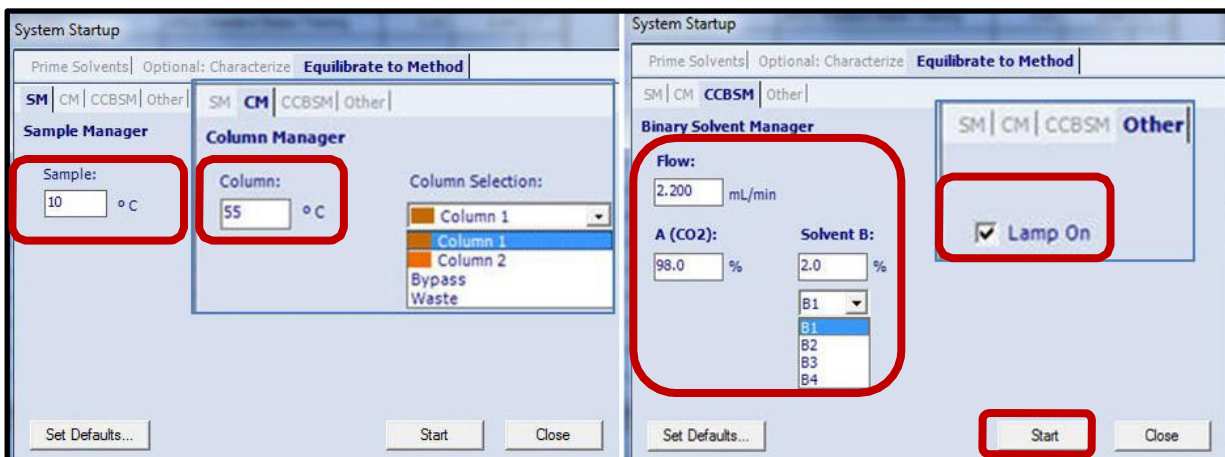

7. UPC<sup>2</sup> operation uses the following 3 step process to keep the CO<sub>2</sub> in a liquid-supercritical state:

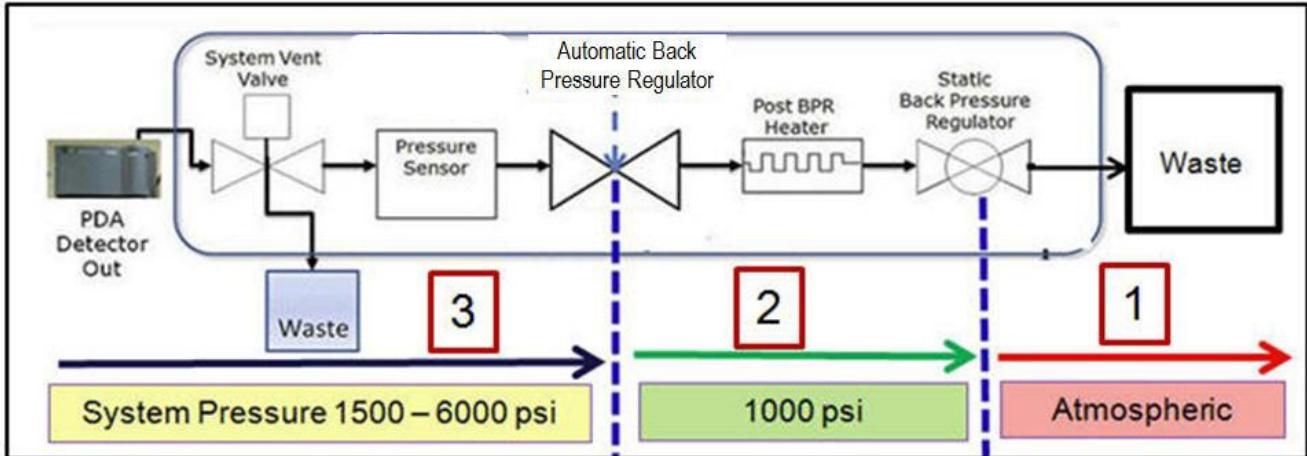

- a. Step 1: Flow rate is turned on and the Static Back Pressure Regulator cartridge builds pressure to ~1100 psi.
  - b. Step 2: The ABPR (Automatic or Dynamic Back Pressure Regulator) is activated once the system pressure reaches ~1100 psi and holds the system pressure constant between pressures of 1500 - 6000 psi (recommended 1700 - 3000 psi). The ABPR uses a solenoid with a needle and seat.
  - c. Step 3: Post ABPR (DBPR) Heat Exchanger – heats mobile phase at the outlet of the ABPR to prevent CO<sub>2</sub> from being exhausted as dry-ice.
8. Incoming CO<sub>2</sub> pressure is required to be above ~750 psi (room temperature dependent) and will be displayed in the Convergence Manager Console display (after the pump is started). The following warning signs will be displayed:
- a. CO<sub>2</sub> inlet pressures between ~ 650-750 psi are displayed with a “yellow warning icon”.
  - b. CO<sub>2</sub> inlet pressures less than ~650 is displayed in red and will not allow system operation.





## F: UPC<sup>2</sup> Instrument Methods and Method Sets

1. UPC<sup>2</sup> Instrument Methods and Method Sets are already developed for the training sample analysis. The following is an overview for each of the Instrument modules that are part of the UPC<sup>2</sup> system.
2. Empower has multiple ways to create methods and acquire data. The procedure below is one way to create an Instrument Method and Method Set.
3. From the menu bar select “Edit - New Method Set”. This is used to create the Instrument Method and Method Set.

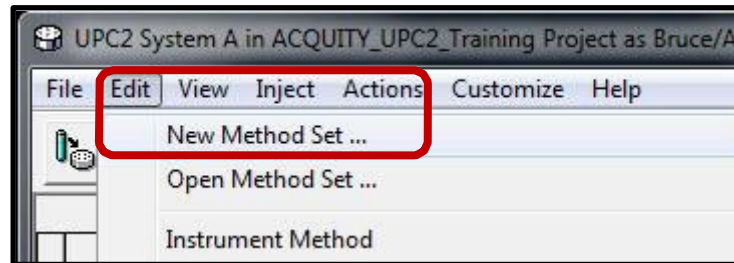

4. The Method Set Editor will be displayed; select “Yes” to use the wizard to create the Method Set (the Method Set includes the Instrument Method and optionally the Processing Method and Report Methods).

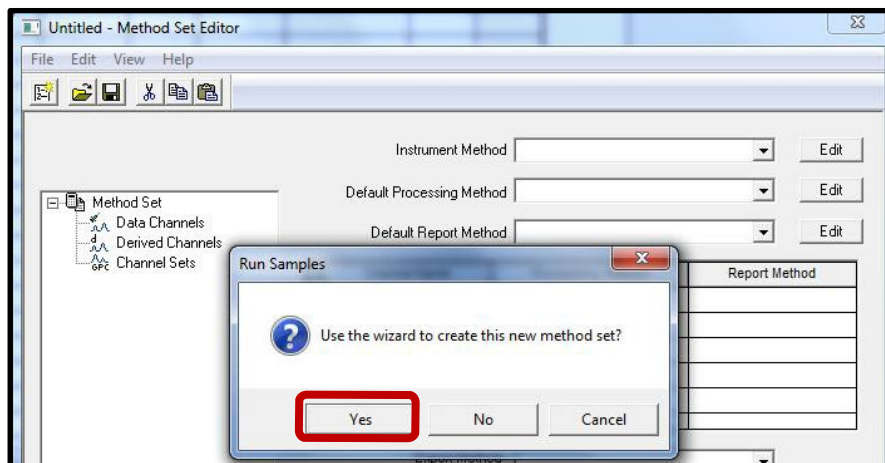

5. If an existing Instrument Method has been created, then select the desired method from the drop down select box. For new methods select “Create New”.

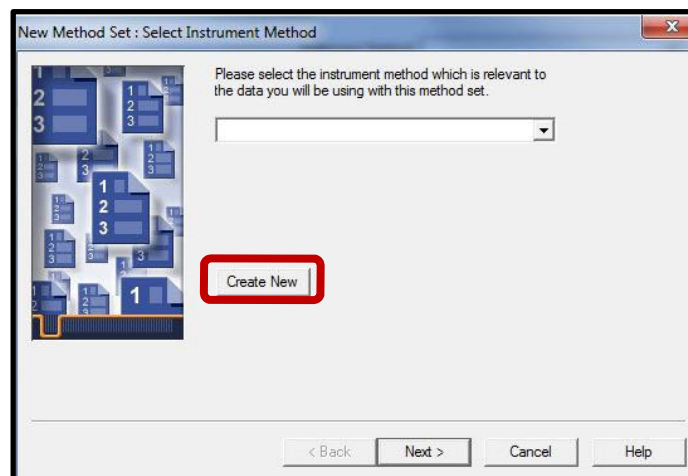

6. The UPC<sup>2</sup> system with PDA has 5 different instrument modules.

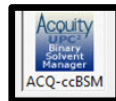
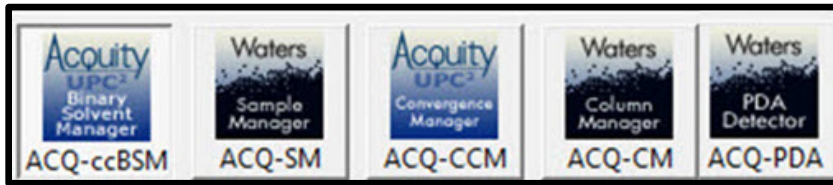

7. Click the ACQ-ccBSM icon to setup the Gradient and Pump conditions. Conditions below are generic for method development using a 3.0 x100cm 1.7um Torus 2-Pic column.

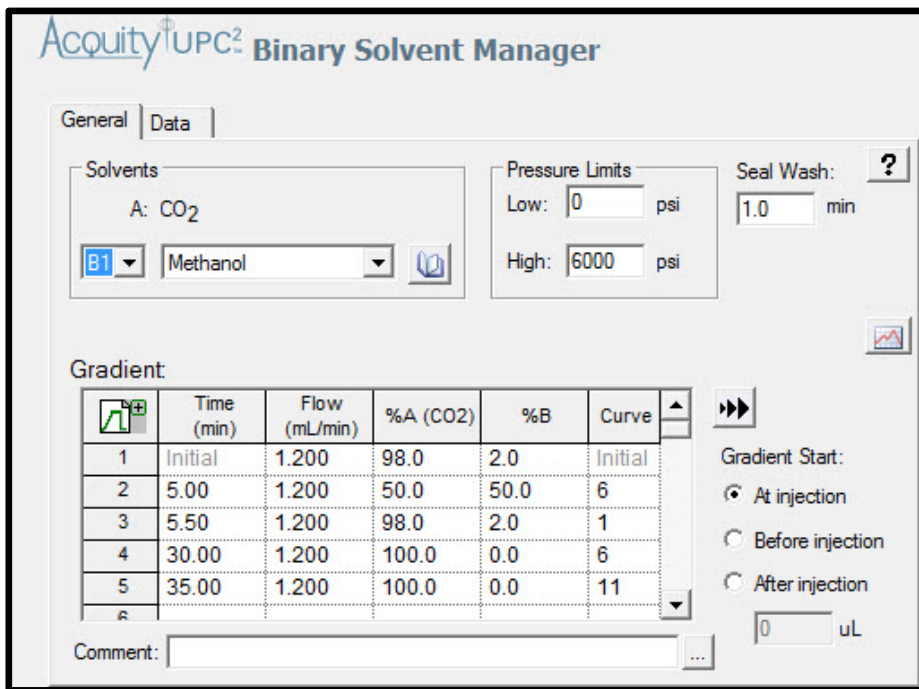

8. General ACQ-ccBSM recommendations:

- a. See the chart below for Torus general flow rate recommendations.
- b. Use IPA as the pump Seal Wash and frequency of 0.5mls/minute.
- c. SFC columns should be stored in 100% CO<sub>2</sub>. Use to 100% CO<sub>2</sub> for 3 minutes.

Column Dimensions (mm)	100% CO <sub>2</sub>		60/40 CO <sub>2</sub> /MeOH	
	Predicted max flow rate (mL/min)	Predicted max pressure (psi)	Predicted max flow rate (mL/min)	Predicted max pressure (psi)
2.1 x 50 mm	3.20	5943	1.55	5928
2.1 x 75 mm	2.25	5925	1.05	5915
2.1 x 100 mm	1.75	5995	0.80	5949
2.1 x 150 mm	1.20	6030	0.55	6053
3.0 x 50 mm	3.75	4295	2.95	5970
3.0 x 75 mm	3.50	5157	2.10	6026
3.0 x 100 mm	3.25	5938	1.60	5991
3.0 x 150 mm	2.30	5947	1.10	6048

Table 3. Useable flow rate ranges and expected ACQUITY UPC<sup>2</sup> System pressures with Torus 1.7 μm Columns.

9. Gradient recommendations: Start from 2% to 40-60% co-solvent – application dependent.

- The stronger the polarity of the co-solvent, the shorter the retention time.
- Changing the % co-solvent changes:
  - Polarity of the mobile phase (becomes stronger).
  - Density of the mobile phase (becomes greater).
  - Both factors contribute to a decrease in retention time.

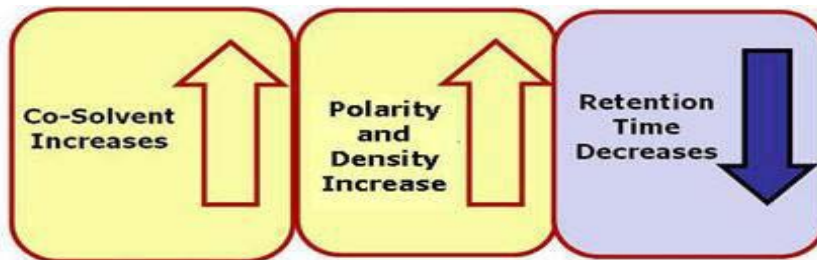

a. Mixtures of CO<sub>2</sub> and co-solvents are supercritical in the column when:

- Co-solvent percentages are approximately less or equal to 20%.
- Co-solvents percentages above 20% may create mixtures that are mostly liquid phase and will affect retention times, but not in a linear fashion.
- High % co-solvents affect the flow rate range because of pressure limitations.

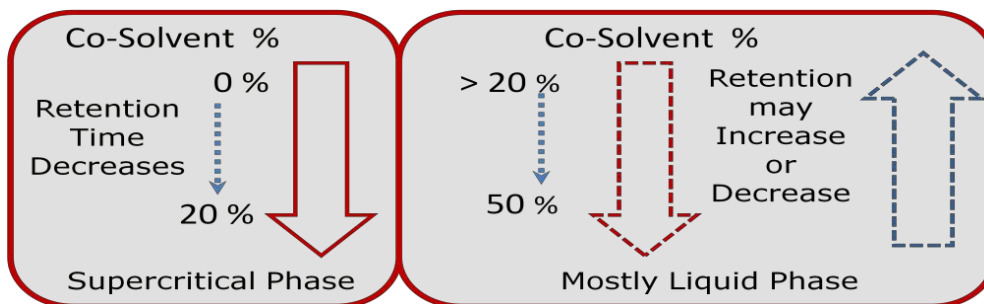

b. Example co-solvents are listed below (most common are in Bold):

<b>Solvents</b>	<b>Polarity</b>	<b>Solvents</b>	<b>Polarity</b>
Isobutyl Alcohol	4	1 Propanol	3.9
Tetrahydrofuran	4	Methanol	5.1
Ethyl Acetate	4.4	Ethanol	5.2
Heptane	0.1	Acetonitrile	5.8
n-Hexane	0.1	Isooctane	0.1
Isopropyl Alcohol	3.9	MTBE (methyl tertiary-butyl ether)	1.24
DMSO Dimethyl Sulphoxide	4.4	NMP (N- Methyl Pyrrolidone)	
DMF Dimethylformamide		DMA Dimethyl Acetamide	
Heptane/IPA (90:10)		Heptane/IPA (70:30)	
<3% Water		Methanol/IPA (50:50)	

- c. Co-solvent additives (buffer salts, acids and bases) can improve peak shape and change retentivity of polar compounds.
- Basic additives improve peak shape and/or elution of basic analytes.
  - Acids additives improve peak shape and/or elution of acidic analytes.

Recommended additives for Torus Column chemistries	20 mM NH <sub>4</sub> OH (Ammonium Hydroxide)	20 mM Am. Ac. (Ammonium Acetate)	0.2% TFA (Trifluoroacetic acid)
Torus 2-PIC (2-Picolylamine)	✓	—	✓
Torus DIOL (High density Diol)	—	✓	✓
Torus DEA (Diethylamine)	✓	—	—
Torus 1-AA (1-Aminoanthracene)	✓	✓	✓

10. Select the proper sample diluent your sample.

- a. For aChiral samples use ~0.2 – 0.5 mg/ml concentration.
- b. For Chiral samples use ~0.4 – 0.8 mg/ml concentration.
- c. For polar compounds:
  - Regardless of column type use a non-polar diluent (Heptane)
- d. For non-polar compounds:
  - If you have a non-polar a-chiral column, use a polar diluent (Acetonitrile)
  - If you have a polar a-chiral column, use a non-polar diluent (Heptane).
- e. For mixed mode samples that have both polar and non-polar compounds consider:
  - Heptane /IPA (90:10) or Heptane /IPA (90:30) or other mixed – mode mixtures.

Solvents	Polarity	Solvents	Polarity
Isobutyl Alcohol	4	1 Propanol	3.9
Tetrahydrofuran	4	Methanol	5.1
Ethyl Acetate	4.4	Ethanol	5.2
Heptane	0.1	Acetonitrile	5.8
n-Hexane	0.1	Isooctane	0.1
Isopropyl Alcohol	3.9	MTBE (methyl tertiary-butyl ether)	1.24
DMSO Dimethyl Sulphoxide	4.4	NMP (N- Methyl Pyrrolidone)	
DMF Dimethylformamide		DMA Dimethyl Acetamide	
Heptane/IPA (90:10)		Heptane/IPA (70:30)	
<3% Water		Methanol/IPA (50:50)	



11. Click the UPC2 Sample Manager icon to setup the injections. Conditions below are for generic configuration of UPC2 Injections.

- a. Sample Temperature settings:
  - Sample temperature settings greater than the freezing point of the sample diluent (DMSO diluents temperatures ~20C).
- b. General Wash Solvents:
  - Generic Wash: Use the same solvent for the weak and strong washes as the co-solvent used in the method.
  - Alternative Wash (sample dependent): 60 MEOH/40 IPA
- c. UPC<sup>2</sup> Sample Manager uses only PLUNO (Partial Loop Needle Overfill). PLUNO is detailed below:
  - Automatic settings require 15 ul of additional sample.
  - Uses 14ul of Needle Overfill pre-sample draw (this may be adjusted in the "Advanced" icon button of the Sample Manager).
  - Uses 1ul of Needle Overfill post-sample draw (cannot be adjusted or changed).
  - No Weak Wash is injected in to column – only mobile phase and sample injected.
  - Air gaps are not injected into column.
  - Sample does not come into contact with weak wash.
  - Recommended range for injection size is 25-75% of the loop volume.
  - Other Injection modes are not supported with UPC2.
- d. Load Ahead: minimizes the injection cycle time of samples through the system.
  - The sample manager overlaps the sample preparation portion of the injection cycle for the next sample while injecting the current sample for analysis.
  - For UPC2 Load Ahead, do not use the "Loop Offline" parameter.
  - Note: The first injection of a sample set, and injection sets with different methods, cannot utilize the load-ahead mode.





12. Click the ACQ-CM icon to setup valve positions and temperatures.

a. Click the "Advanced function to setup columns for 2 separate temperatures.

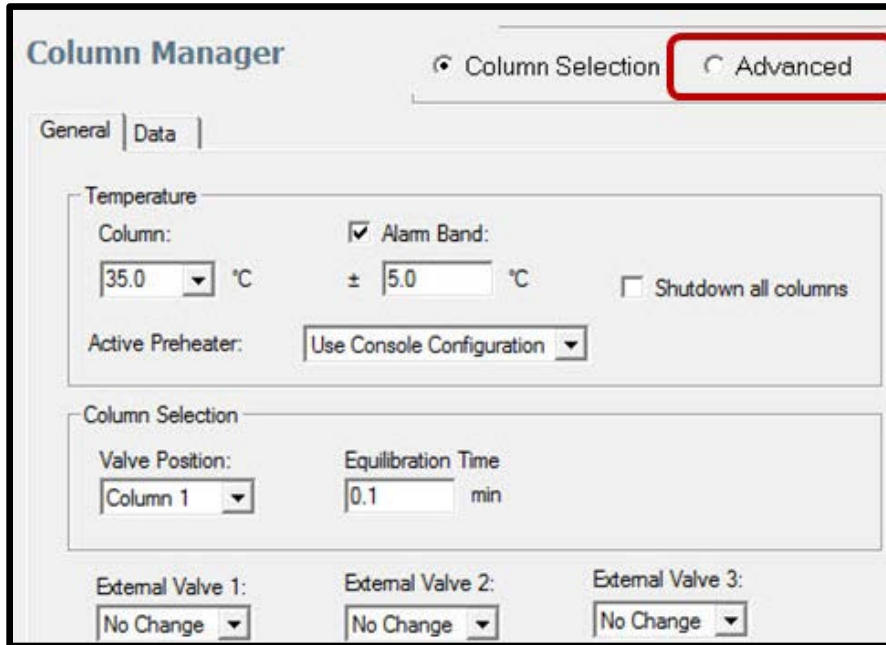

b. In the Advanced Column Manager tab. The advanced tab is used to configure 2 different column temperatures (Up to 6 if you have the CM-Aux configurations).

- Select "Valve Position" of both valves to "No Change". This allows column switching to be selected in the "Sample Set Method".
- If you select specific valve positons, you will need to make specific instrument methods for each column position.

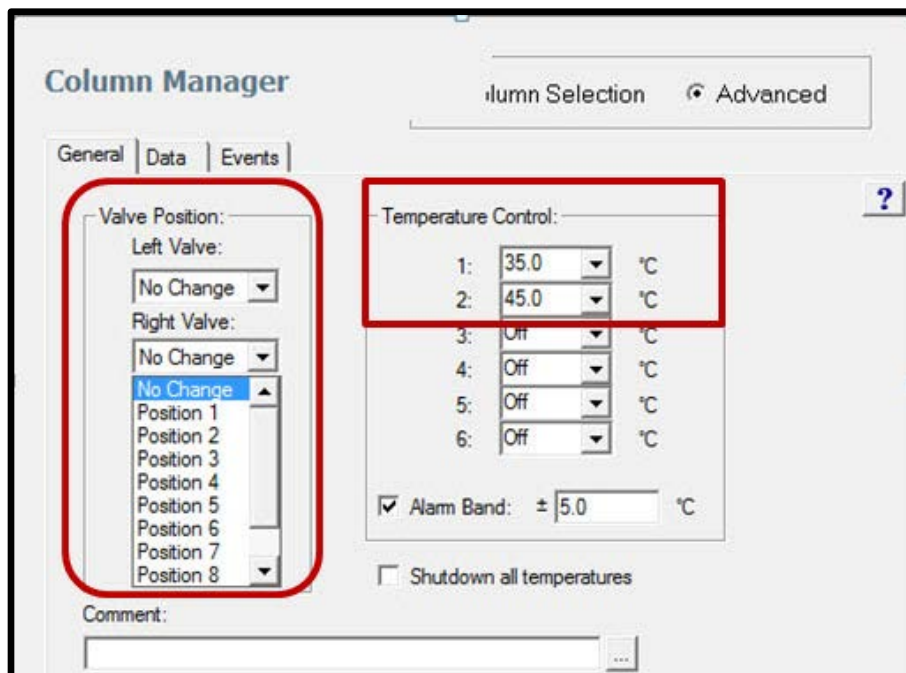



- c. General UPC<sup>2</sup> Column Temperatures details: SFC Separations are affected by the density in the column. Higher Column temperatures decrease density and increase retention time. Lower column temperatures increase density and decrease retention time.

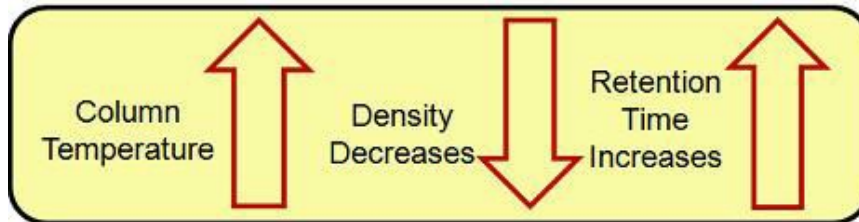

- Recommended column temperatures ranges for UPC2 are from 25-65C.
- A column temperature below 35C takes the CO<sub>2</sub> out of the supercritical phase, though as long as the pressures are above 1500 psi, the separation should work.



13. Click the UPC<sup>2</sup> PDA icon to setup wavelength range, resolution and data rate.

The screenshot shows the 'PDA eλ Detector' configuration window. It has tabs for 'General', '2D Channels', 'Analog Out', and 'Events'. The 'General' tab is active. There is a 'Lamp On' checkbox which is checked. Below it is an 'Enable 3D Data' checkbox, also checked. The 'λ Range' is set to '210 nm to 400 nm'. The 'Resolution' is set to '1.2 nm'. The 'Sampling Rate' is '20 points/sec', 'Filter Time Constant' is 'Normal', and 'Exposure Time' is 'Auto msec'. There are checkboxes for 'Interpolate 2nd order filter Region', 'Interpolate 656 nm Line Region', and 'Use UV blocking filter (below 210nm)'. The 'Negative Absorbance Margin' is set to '-0.07 AU'. There is a 'Comment:' field at the bottom.

- a. For 3D data and spectral analysis:
- Collect a wavelength range wide enough to include all spectral information for each component. Usually start at 210nm or greater – dependent upon co-solvent.
  - Use a resolution of 1.2nm for Peak Purity and Spectral Library investigation.
  - Sample rates should be ~10 -20 points a second for most analysis conditions (peak integration/quantitation requires peaks a minimum of 15 points across a peak).

- Leave the Filter time at the default settings (automatically adjusts).
- The negative absorbance margin is needed when the absorbance baseline saturates or exhibits a flat, noiseless trace within the chromatogram.

- b. The 2D Channels tab can extract up to 8 individual wavelengths.
- c. The refractive effects of CO<sub>2</sub> can produce baseline disturbances. "Absorbance-Compensated" 2D collection is used to account for refractive index disturbances. Use Compensated Reference of "380-480" to subtract this from the chromatogram.

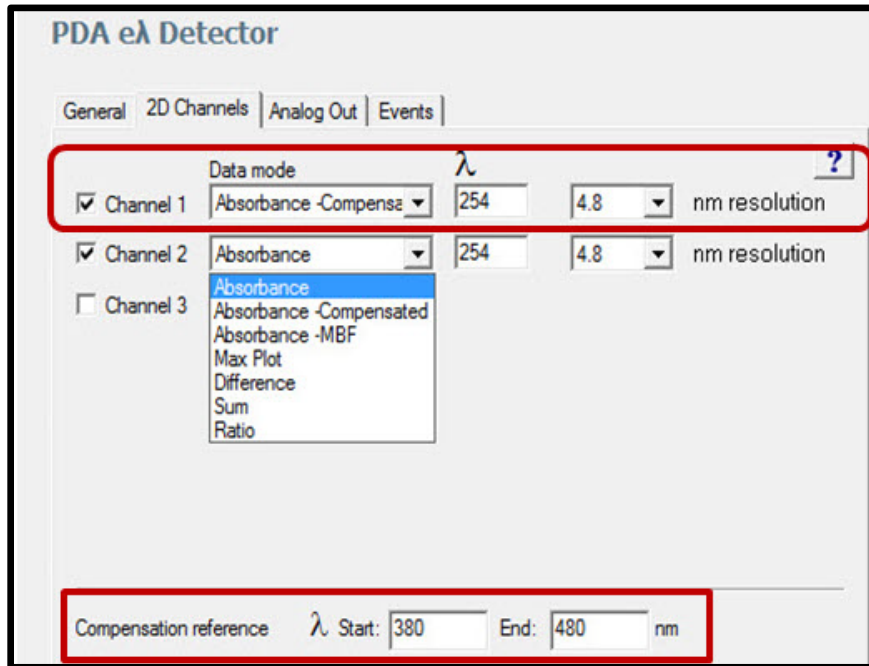

- d. The Chromatograms below show how "Compensation Reference" works.

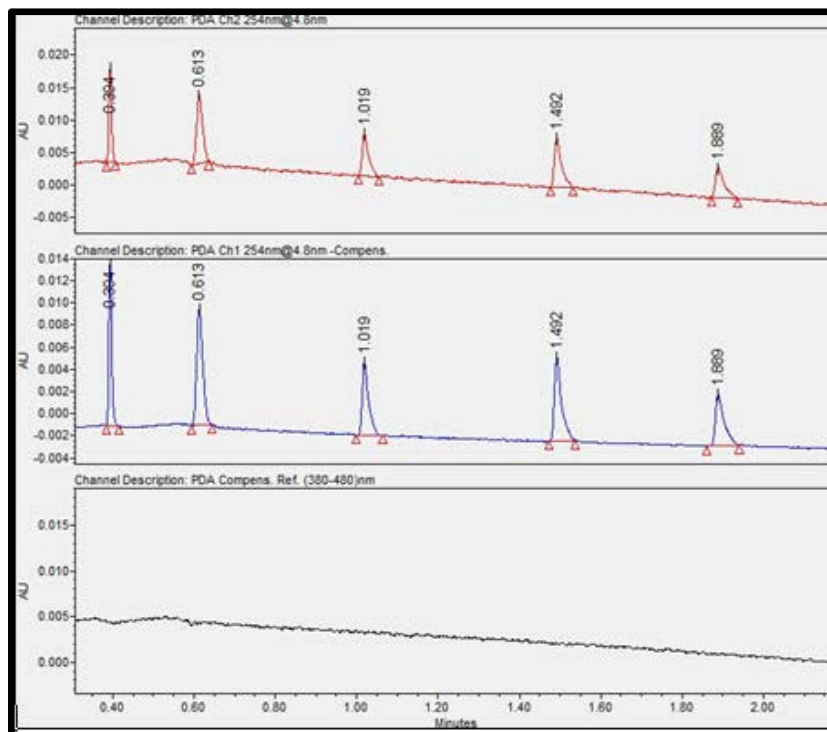



14. Click the UPC<sup>2</sup> Convergence Manager to setup the ABPR system backpressure. This is used to keep the CO<sub>2</sub> in a liquid/supercritical state during the analysis (1500 psi -6000 psi).
- a. 2000 psi is a good ABPR pressure start point.

Acquity<sup>+</sup>UPC<sup>2</sup> Convergence Manager

General | Data

ABPR Pressure ON

Pressure Gradient:

	Time (min)	Pressure (psi)
1	Initial	2000
2		
3		
4		
5		
6		
7		

Comment:

- b. SFC Separations are affected by density. The ABPR back pressure settings affect retention time by changing the density before the release of pressure.
- c. As ABPR pressure increases, the density increases and retention time will decrease.
- d. Lower Pressures than 1600 may affect the separation in a non-reproducible way as the condition changes from a supercritical phase to a more gaseous phase – which then affects the polarity and density.
- e. Higher pressures than 3500 may prohibit the pressure drop for the column. ABPR pressure is another dimension that can be used in developing methods and separations.

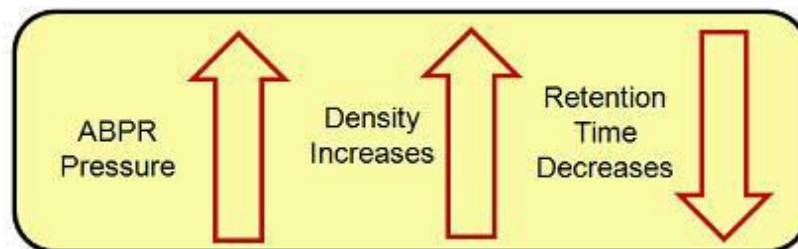

- f. General settings for the ABPR are between 1600-3500. Gradients may be used, though not required.

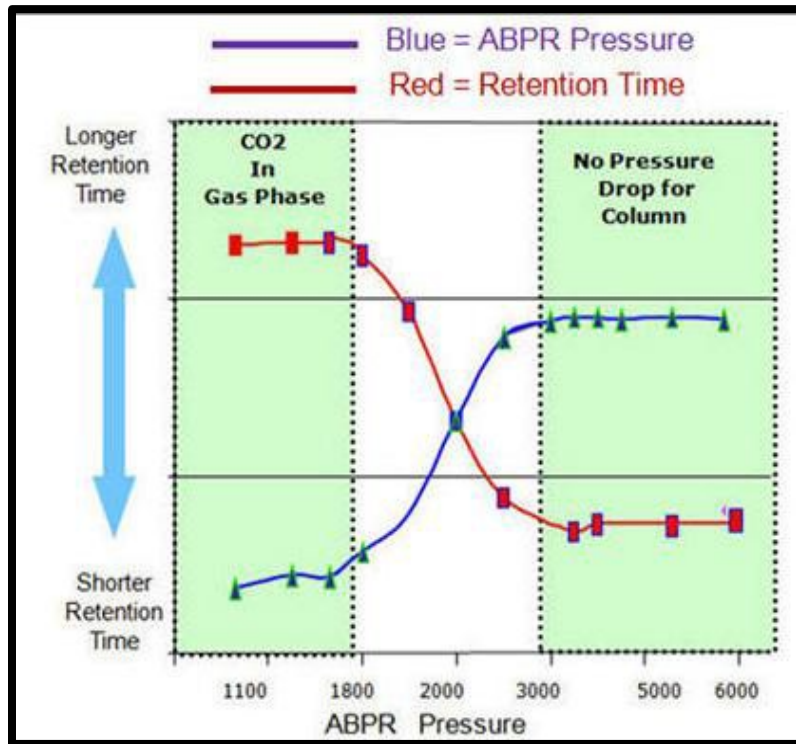

- g. Select the Data tab of the Convergence Manager.

- Select ABPR pressure and CO2 inlet pressure data channels.
- These can be used for diagnosing instrument acquisition issues.

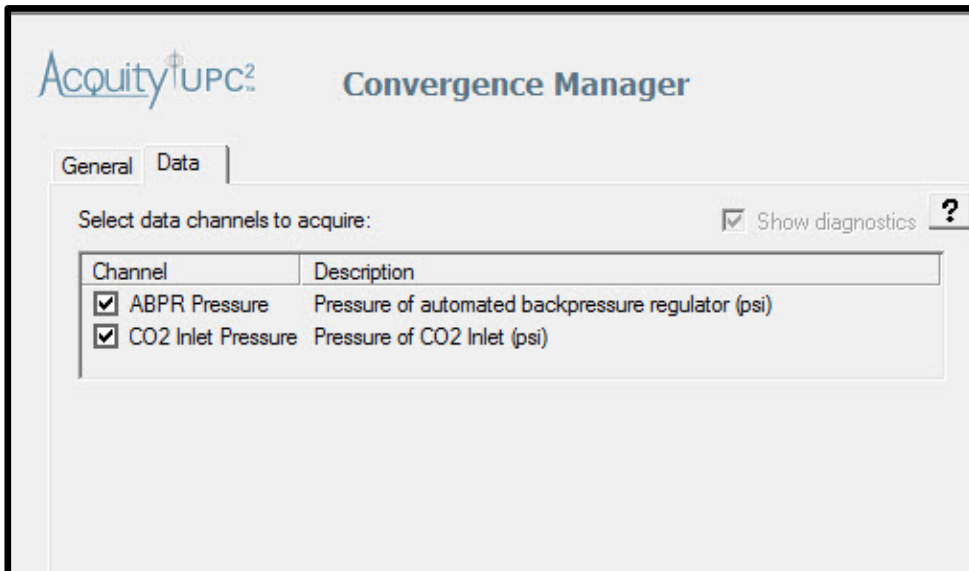

15. Select the desired Instrument Name in the list, and then select **Next**.

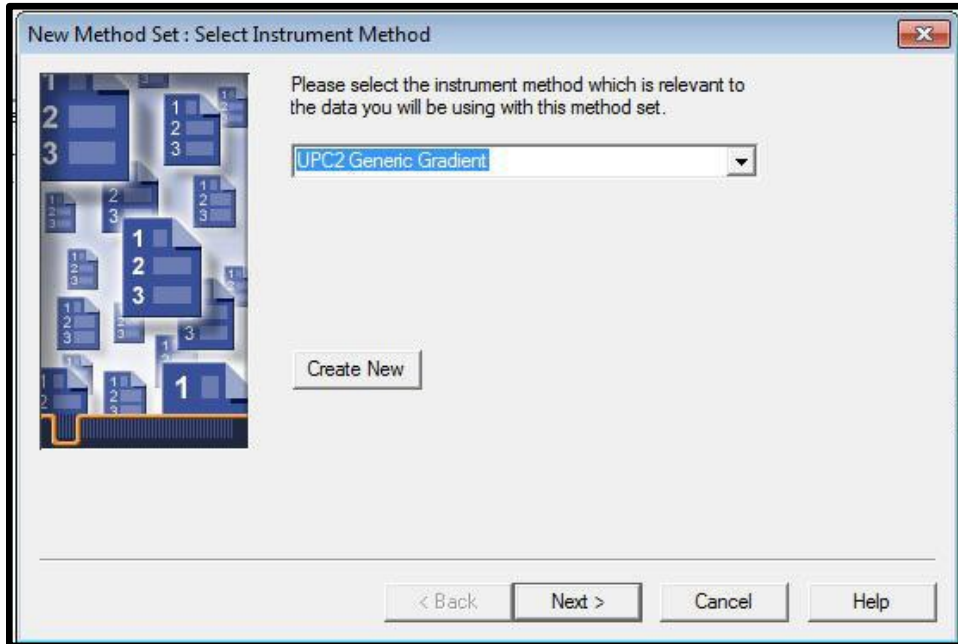

16. Select the desired Processing Method and Report Method, and select **Next**.

Note: The UPC<sup>2</sup> training project has a basic default processing method and report method. For the training select these two methods.

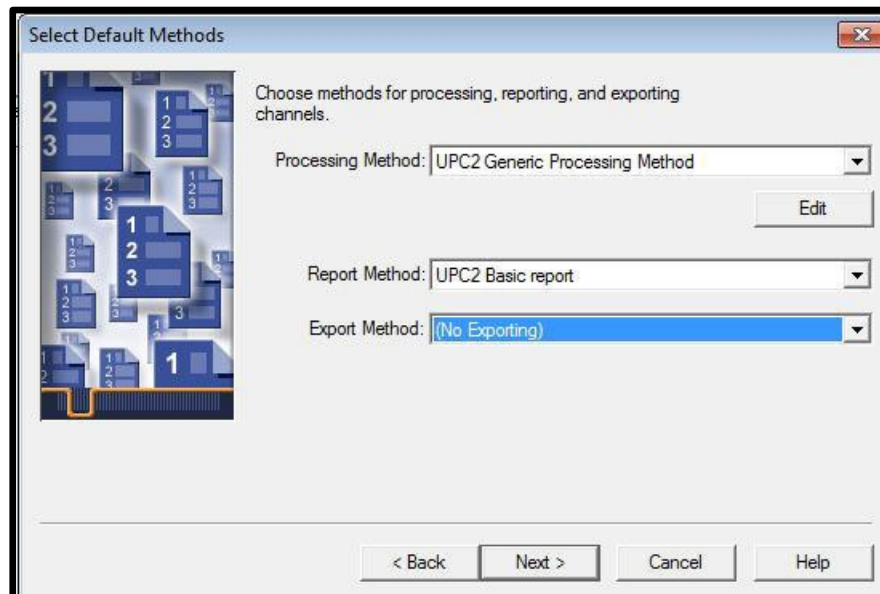

17. Optionally Click "Define PDA Derived Channels". This may be bypassed since 2D wavelength was selected in the UPC<sup>2</sup> instrument method. Click Next.

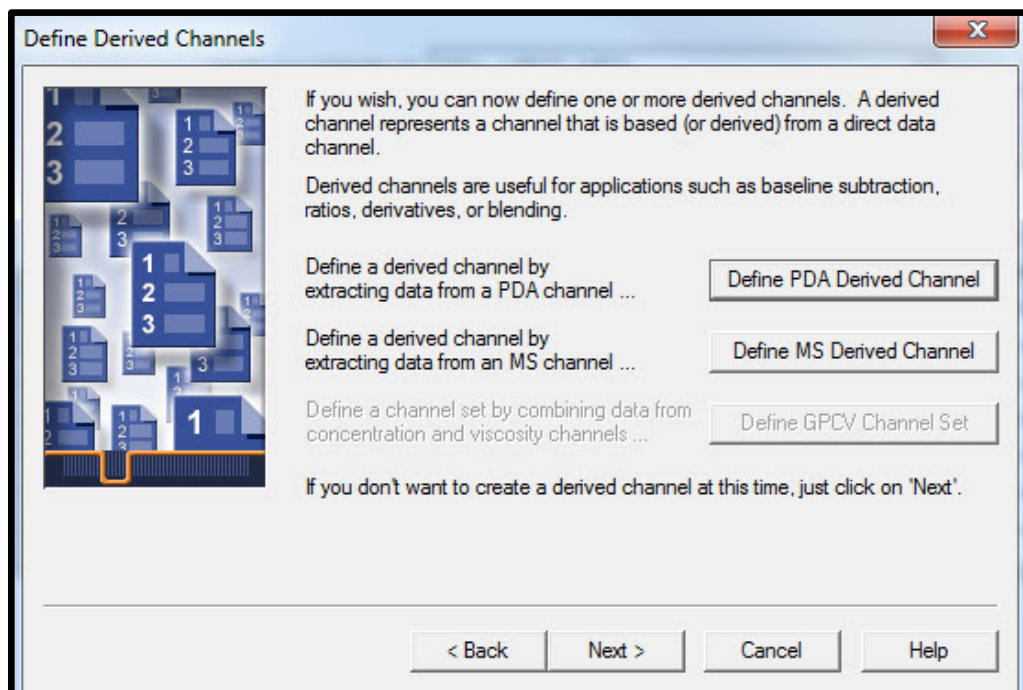

18. Save the Method Set and click Finish.

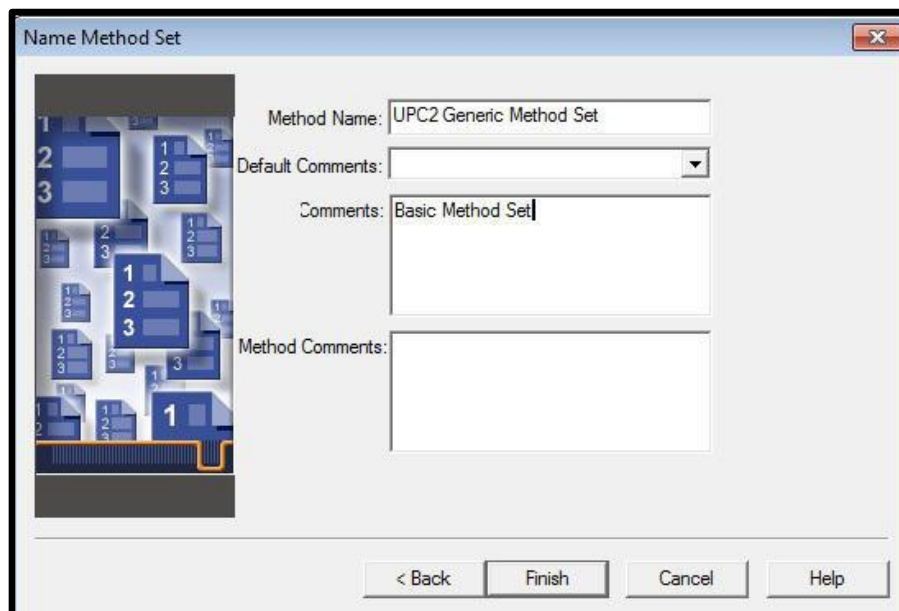

19. You have now completed the basics of the Instrument method and Method Set.











- b. Select "File – Exit" to exit the Component Editor. Select "File – Save" to save the changes to Process Only Sample Set, and then File – Exit to the Project View.

9. Select File-Save Sample Set then select the  button to start the Sample Set.

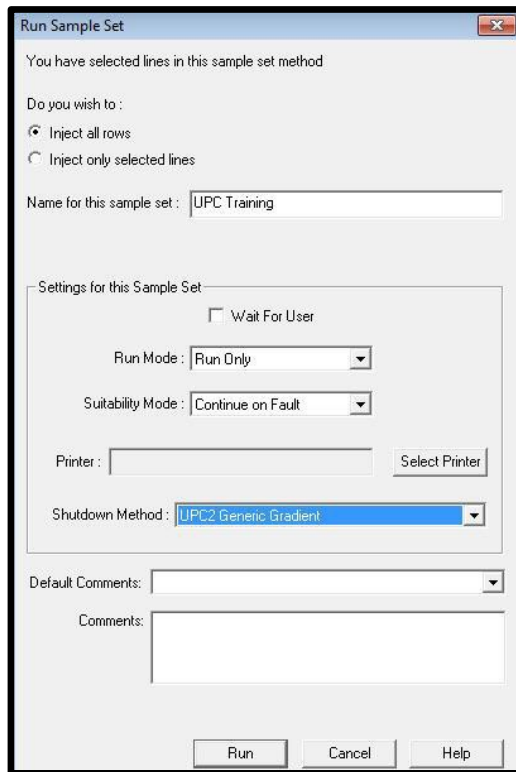
10. Enter the Sample Set information as desired and select "Run" to start the Sample Set. You have now completed the basics to acquire UPC<sup>2</sup> data with Empower.



## H: ACQUITY UPC<sup>2</sup> Console and Diagnostics

1. The ACQUITY UPC<sup>2</sup> console can be used for diagnostics and system checks of the UPC<sup>2</sup> System.
2. Access the UPC<sup>2</sup> console by clicking on the Sample Manager's  in the Run Samples window.



3. The main console screen has a general status screen for each of the UPC<sup>2</sup> modules.
  - Each module can be selected for more detailed information as well as specific diagnostic checks.

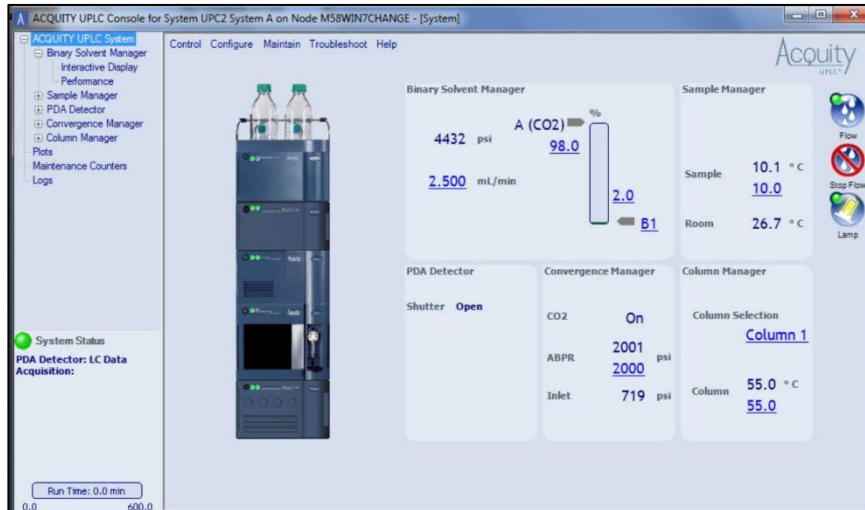

4. For issues that need support and assistance, use Troubleshoot – “Connections Insight” or “Save Service Profile”.
  - Save Service Profile can be emailed to Waters support for troubleshooting issues.
  - Service and method details are sent in a zipped file with no chromatographic data.

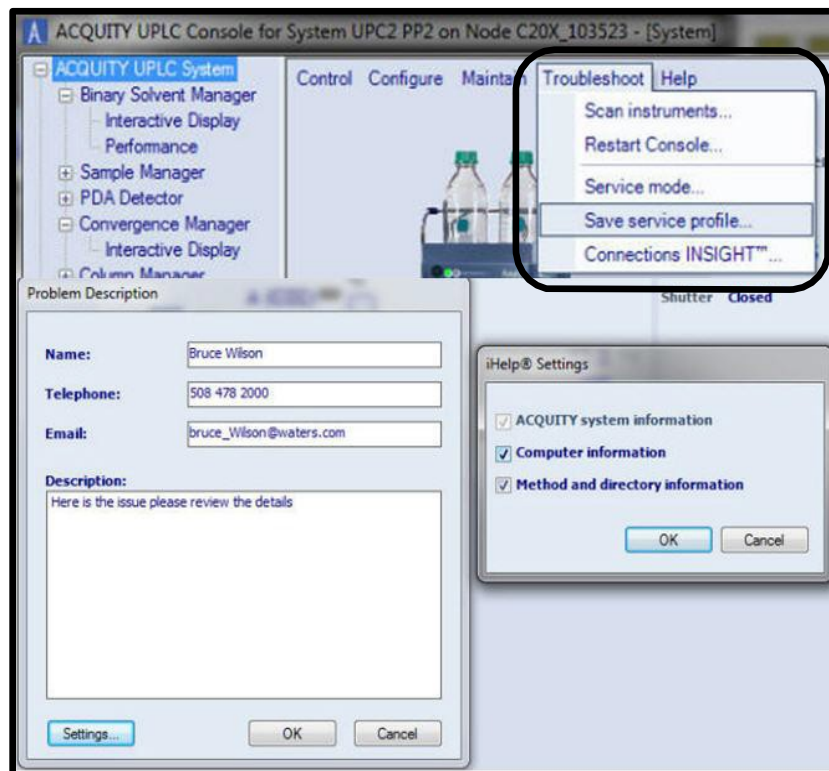



5. UPC<sup>2</sup> BSM - Main display screen diagnostic and performance checks:

- Pressure Ripple (Isocratic conditions) Delta should be <= 1-2% of system pressure. If greater than this, re-prime co-solvent pump and perform the Dynamic Leak Test (step b).

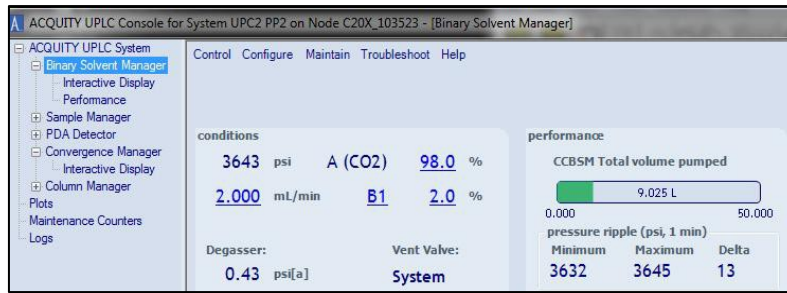

- Select the Binary Solvent Manager – Maintain – Dynamic Leak Test.

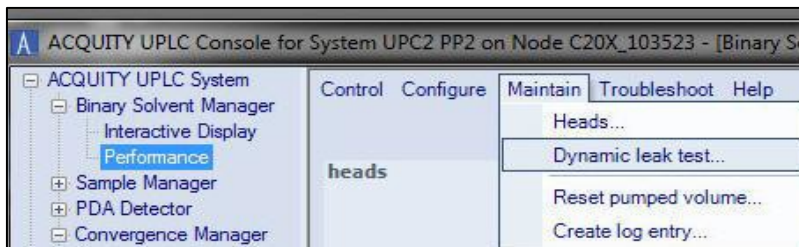

- Select the Pump to test and click Prime. Leave the default test conditions and select "Start".

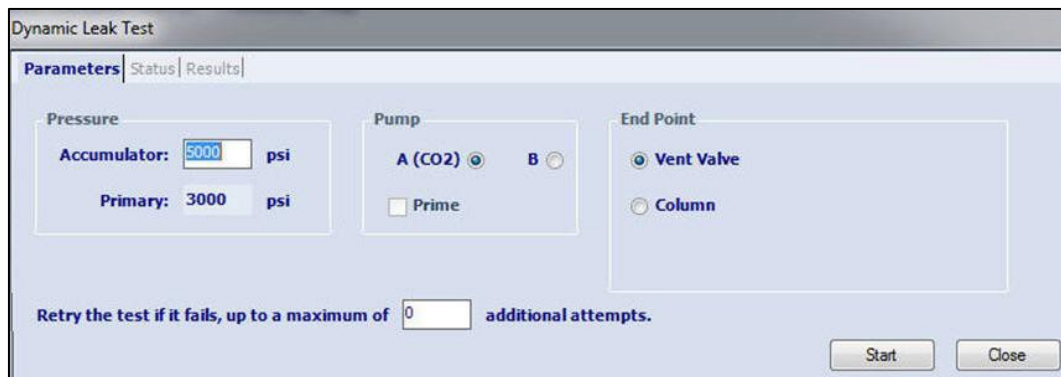

- The results for the Accumulator and Primary will be displayed as below. If the results fail – re-prime and try again. If the leak fails again, contact your Waters Service engineer.





- Use the UPC<sup>2</sup> BSM –Interactive Display to confirm the BSM CO<sub>2</sub> cooling temperatures for the Primary pump is at 2.0 C (-0.5 +2.0) and the Actuator pump is at 13.0 C (+/- 2.0). If the temperatures are beyond the range, contact Waters technical services for support.

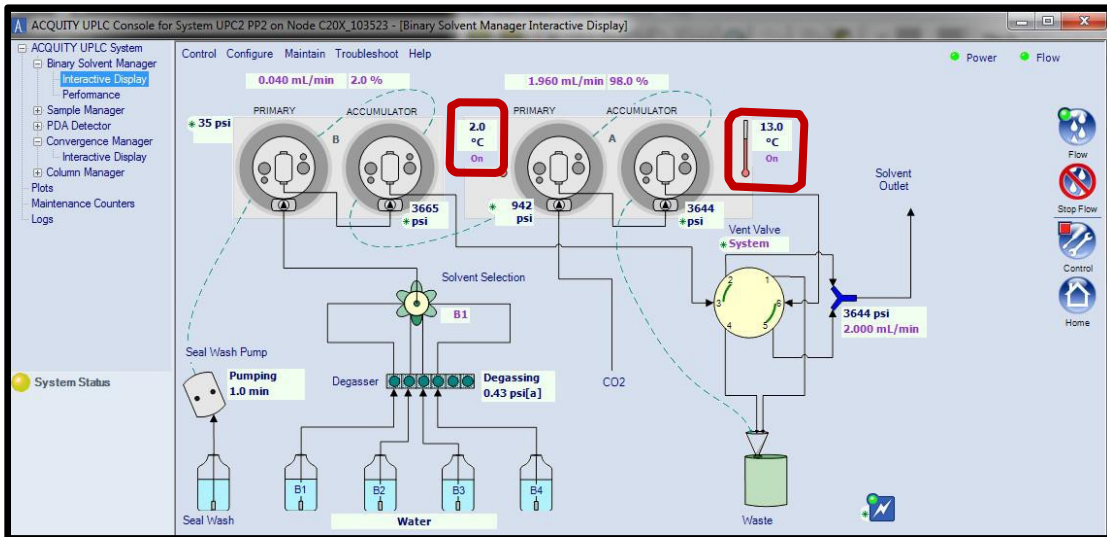

6. UPC<sup>2</sup> Convergence Manager - Main display screen diagnostic and performance checks:

- ABPR pressures fluctuations should be <= 1% of ABPR pressure settings (\*1). If fluctuations occur above 1% check the following:
  - Check the inlet pump pressure
  - Make sure CO<sub>2</sub> inlet pressure is within acceptable ranges (\*2). Out of range pressures will be colored coded.



- Check for leaks at the column and all connectors
- Check ambient CO<sub>2</sub> (\*3). If this is high, there may be a leak internal to the Convergence Manager. Contact Waters service.
- Complete the Convergence Manager's ABPR Health test (step 7)

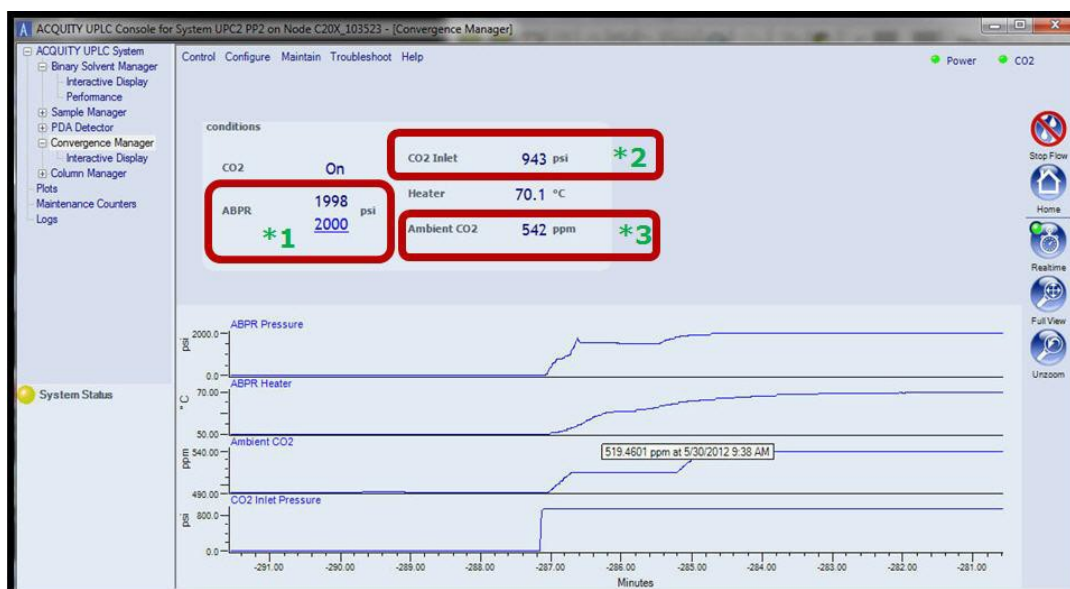

7. UPC<sup>2</sup> Convergence Manager ABPR Health Test. This should be used if the ABPR pressure settings cannot be reached and maintained. Select from the Convergence Manager, Troubleshoot-ABPR health test.

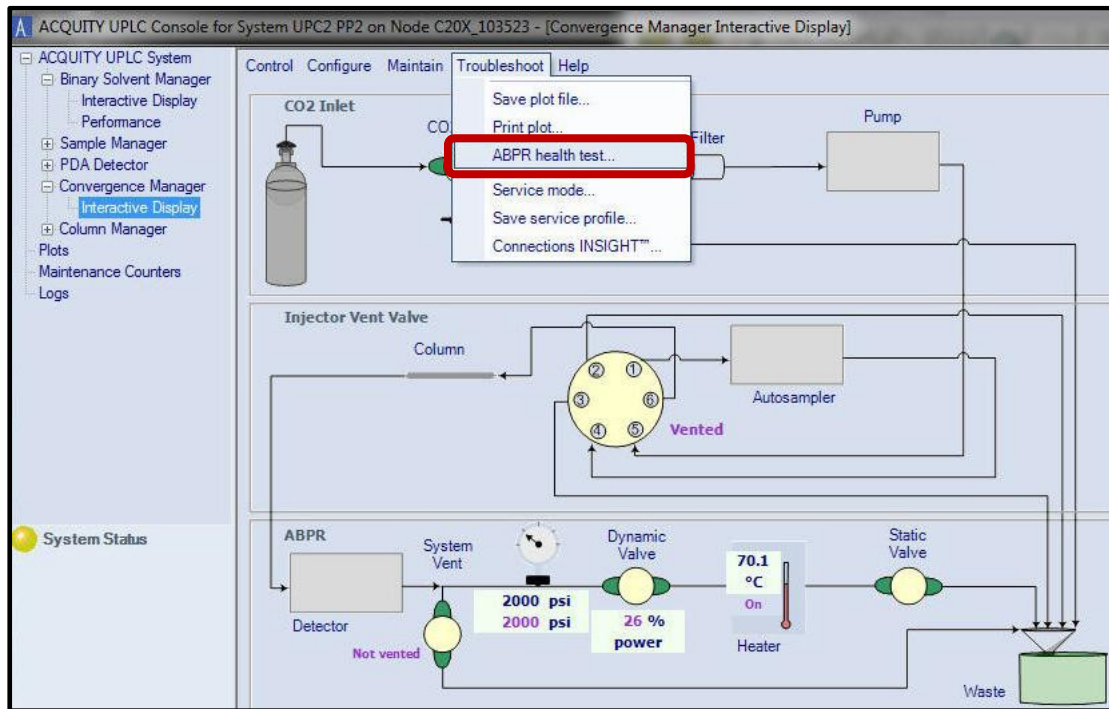

8. The ABPR Health Test executes the following consecutively (takes about 6 minutes):

- Part 1 - Tests the Static Back Pressure Regulator
  - Sets the Column Manager to the Bypass position and turns off the ABPR.
  - Sets the BSM flow rate to 100% CO<sub>2</sub> (pump A) at 3 ml/min and 1ml/minute for 2 minutes each.
  - Check and ensures the values read are greater than 1000 psi to 1400 psi. If the Static test fails, the Static cartridge will need to be changed.
- Part 2 - Tests the Dynamic Back Pressure Regulator
  - Keeps the Flow at 1.0 ml/min 100% CO<sub>2</sub> (pump A) and uses the Column Manager Bypass position.
  - Sets APBR power to 45%
  - Waits 2 minutes and confirms the APBR pressure is between 3000 & 5000 psi. If the Dynamic test fails, contact Water's Service.

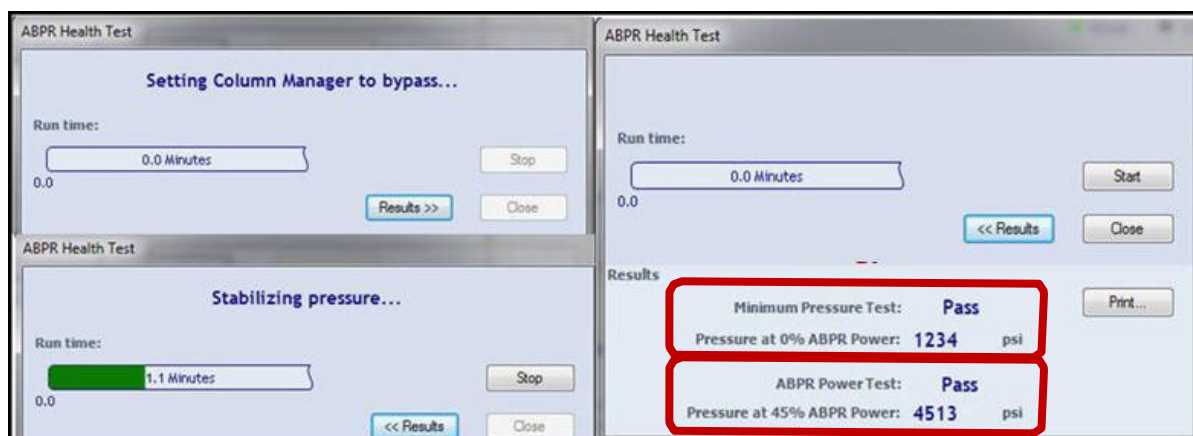

9. Additional ACQUITY UPLC console items to check:

- View the Logs and select to see "All" content for errors or issues, or choose another content category.
- View the Plots and view the various plots.

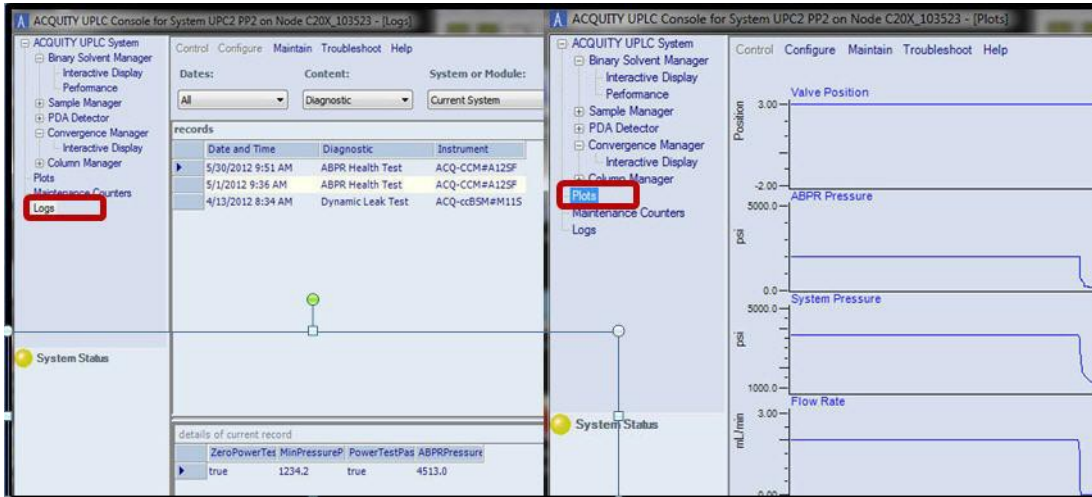

10. For other ACQUITY UPC<sup>2</sup> issues, please contact Waters Expert center or your local Waters Field Service Engineer.